



# ASSEMBLY INSTRUCTIONS

Remove all items from the carton. Verify all pieces before assembly

## PARTS LIST

KEY	QTY	DESCRIPTION	KEY	QTY	DESCRIPTION	KEY	QTY	DESCRIPTION
1	5	Caster	7	1	Backrest	11	10	Armrest Screws (1/4"*1-1/4")
2	1	Base	8	4	Mechanism Screws and Washers (5/16"*1")	12	2	Arm screw caps
3	1	Seat Post	9	4	Back attachment Screws and Washers (5/16"*1-1/4")	13	1	Allen Wrench (5mm)
4	1	Seat Post Cover						
5	1	Mechanism	10	2	Armrest			
6	1	Seat						

STEP 1.

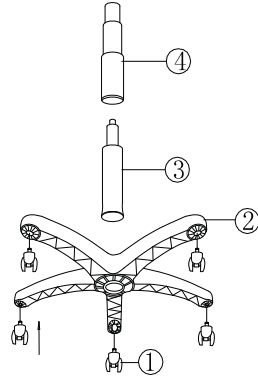

STEP 2.

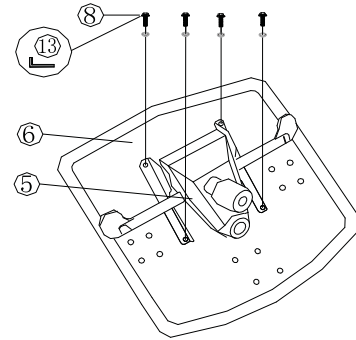

STEP 3.

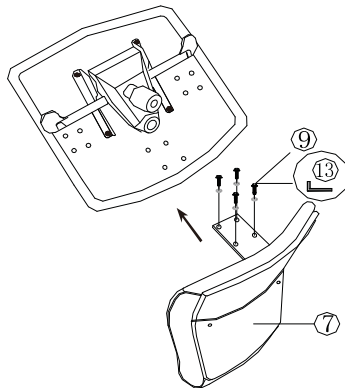

STEP 4.

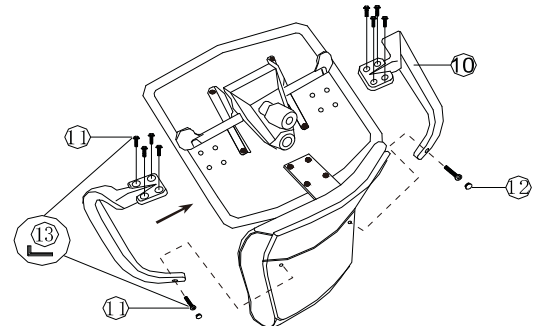

NOTICE:

- (A) ATTACH ARM TO BACK, BUT DO NOT FULLY TIGHTEN SCREWS.
- (B) ATTACH ARMS UNDER SEAT AND THEN FULLY TIGHTEN ALL SCREWS.

STEP 5.



NOTICE:

EVERY 6 MONTHS, PLEASE MAKE SURE ALL BOLTS, SCREWS AND KNOBS ARE FULLY TIGHTENED TO ENSURE STABILITY.

### MECHANISM OPERATION INSTRUCTIONS

#### WHILE SEATED:

- (A) SEAT HEIGHT ADJUSTMENT:  
Pull lever up. Release lever when desired position is reached
- (B) TILT ADJUSTMENT:  
Pull lever up and lean back to tilt. Push lever down to lock in desired position.
- (C) TILT TENSION ADJUSTMENT KNOB:  
Rotate knob clockwise/counterclockwise to adjust tilt tension based on body weight.

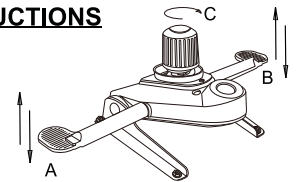

### PREVENTIVE MAINTENANCE AND WARNING!

- USE THIS PRODUCT ONLY FOR SEATING ONE PERSON AT A TIME.
- DO NOT USE THIS CHAIR AS A STEP STOOL/LADDER.
- DO NOT SIT ON ANY PART OF THE CHAIR EXCEPT THE SEAT.
- DO NOT USE CHAIR ON UNEVEN FLOOR SURFACES.
- DO NOT USE CHAIR UNLESS ALL BOLTS, SCREWS AND KNOBS ARE TIGHT.
- AT LEAST EVERY SIX MONTHS, CHECK ALL BOLTS, SCREWS AND KNOBS TO BE SURE THEY ARE TIGHT.
- IF ANY PARTS ARE MISSING, BROKEN, DAMAGED OR WORN, STOP USE OF THE PRODUCT UNTIL REPAIRS ARE MADE USING FACTORY AUTHORIZED PARTS.
- DISPOSE OF PACKAGING PROPERLY, PLASTIC BAG IS NOT A TOY. DO NOT USE PLASTIC BAG AS HEAD COVERING-IT MAY CAUSE SUFFOCATION.
- FAILURE TO FOLLOW THESE WARNINGS COULD RESULT IN SERIOUS INJURY.